

C2101-120 2.5 L internal volume



- ▶ COAX® patented technology.
- ▶ All materials in contact with the conveyed product fulfill the requirements of FDA.
- ▶ Manual dismounting and cleaning.
- ▶ Fully pneumatic.
- ▶ Reusable textile bag filter.

Technical data

Description	Unit	Value
Feed pressure range	MPa	0.4–0.6
Air consumption range	NI/s	5–7
Vacuum range	-kPa	61–75
Noise level range	dBa	70-73
Material		ASTM 316L, Zn, Q, NBR, PA, Al
Temperature range	°C	0–60
Weight	kg	10.23-10.26
Filter area	m ²	0.06
Pipe dimension	mm	Ø32
Material batch volume	l	2.5
Min particle size	µm	5
Capacity at 5 m length	kg/h	500

Ordering information

Description	Art. No.
Conveyor C2101-120 2.5 l int volume, textile filter int, NBR	0121638
Conveyor C2101-120 2.5 l int volume, textile filter int, Q	0121658

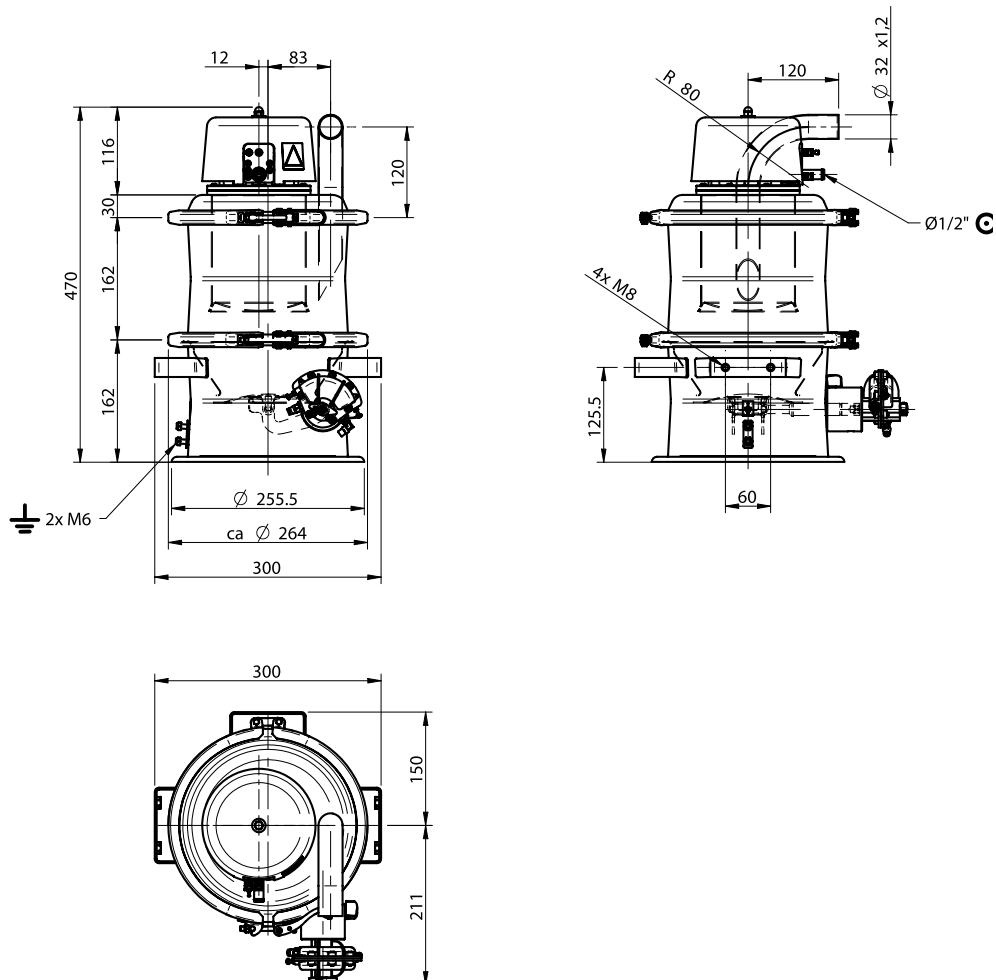

Complete

Ordering information, accessories

Description	Art. No.
Control unit PPT/RS	0111636
Control unit CU-1B, bottom valve NC	0119838
Nylon tubing kit, PPT/R C21	0106980
Nylon tubing kit, fluid, CU-C21	0106979
Regulator kit 1/2" 100-400	0104490