

OBL40x90P



Oval suction cup with 4 bellows

- ▶ Suitable for long, narrow and bent surfaces, for example bottles, pipes or sharply bent sheet parts.
- ▶ Reinforcement plates gives stability to the suction cup.
- ▶ Available in a version with a valve that is activated when the bellows are compressed.
- ▶ DURAFLEX® suction cups manufactured in a specially developed material that features the elasticity of rubber and wear resistance of polyurethane. The material does not leave any marks on the objects handled.

Lifting forces & Technical data

Material	Lifting force vertical to the surface, N, at vacuum level			Lifting force parallel to the surface, N, at vacuum level			Volume cm ³	Min. curve radius mm	Max. vertical movement mm	Weight rubber part g
	20 -kPa	60 -kPa	90 -kPa	20 -kPa	60 -kPa	90 -kPa				
PU60°	44	105	160	40	87	121	105	28	31	77
PU70°	49	117	178	45	97	135	105	28	31	77

Material specifications

Material	Colour	Hardness °Shore A	Temperature range °C
Polyurethane PU60	Green transparent	60	10-50
Polyurethane PU70	Black	70	10-50

Material resistance

Wear resistance	Oil	Weather & ozone	Hydrolysis	Petrol	Concentrated acids	Ethanol	Methanol	Oxidation
Excellent	Excellent	Excellent	Fair**	Fair	Fair**	Fair	Poor	Poor

**Please contact Piab.

Ordering information

	Complete suction cups	Art. No.
A	Suction cup OBL40x90P Polyurethane 60, with 3 reinforcement plates and load support	0106697
B	Suction cup OBL40x90P Polyurethane 70, with 3 reinforcement plates and load support with G3/8" male, filter	0107325

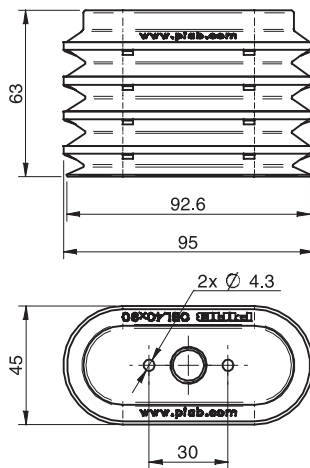

<Picture_Text changed="2004-05-06 13:52:00">A

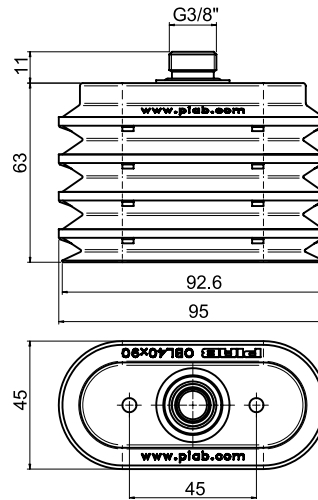

<Picture_Text changed="2004-05-06 13:52:41">B