

P6040 Function ES Blow



- ▶ Patented COAX® technology
- ▶ Substantially lower air consumption
- ▶ Modular design for flexible performance
- ▶ Compact and durable with no moving parts
- ▶ Saves energy when the blow-air requirement varies

Technical data

Description	Unit	Value
Feed pressure	MPa	0.7
Noise level	dBA	57-76
Temperature range	°C	0-50
Signal range	kPa	15-100
Hysteresis	kPa	1-79
Voltage	V	24
Voltage range	V	14-28
Current consumption	mA	60
Ripple	V _p	1 V _{rms}
Safety classification	IP	40
Display		LED
Weight	g	4900-5900
Material		Al, PA, NBR, SS, POM, HDPE, PC, CuZn, PBT

Ordering information

Description	Art. No.
Function ES Blow	0117785
Example	Ordering No.
P6040 Blow, Si32-3X5 with non-return valve, Mounting T-slot, Cover plate with function ES blow, Connection G 2 1/2" with inlet silencer	P6040 B BW 00 AE 08

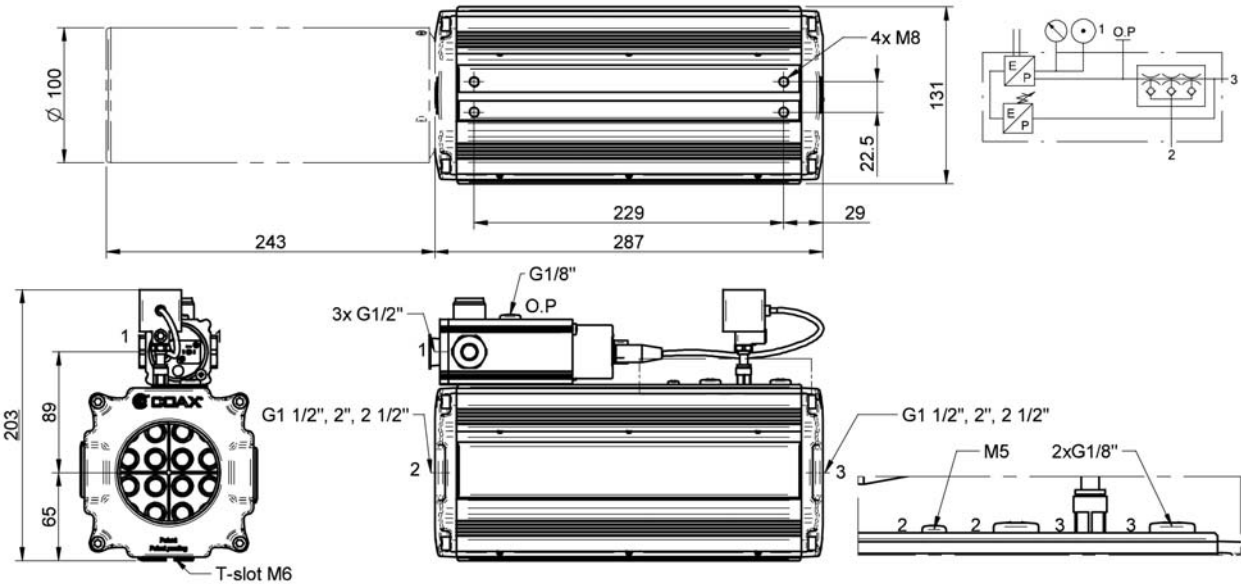

Large