

L200



- ▶ Large vacuum flow
- ▶ Compact size and light weight compared to conventional mechanical pumps
- ▶ Short evacuation time
- ▶ Good for handling porous materials or if leakage is present

Supplied with vacuum gauge and manometer.

Technical data

Description	Unit	Value
Feed pressure, max.	MPa	0.7
Noise level, with silencer	dB(A)	64–78
Temperature range	°C	-20–80
Weight	g	4100–4600
Material		Al, PPS, NBR, SS

Feed pressure MPa	Air consumption NI/s	Vacuum flow (NI/s) at different vacuum levels (-kPa)										Max vacuum -kPa
		0	10	20	30	40	50	60	70	80	90	
0.60	14.0	38	23.0	16.1	11.2	6.5	4.9	3.0	1.1			75

Evacuation time

Feed pressure MPa	Air consumption NI/s	Evacuation time (s/l) to reach different vacuum levels (-kPa)									Max vacuum -kPa
		10	20	30	40	50	60	70	80	90	
0.60	14.0	0.004	0.009	0.016	0.030	0.050	0.070	0.13			75

Blow flow

Feed pressure MPa	Air consumption NI/s	Blow flow (NI/s) at different pressure levels (kPa)									Max pressure kPa
		0	10	20	30	40	50	60	70		
0.60	14	52.0	35.9	31.9	26.8	24.5	23.1	21.1	18.5	70	

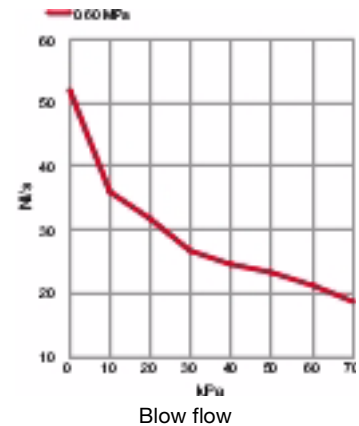
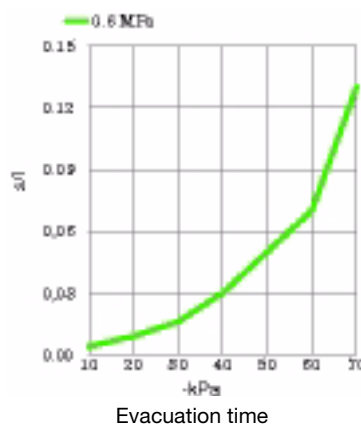
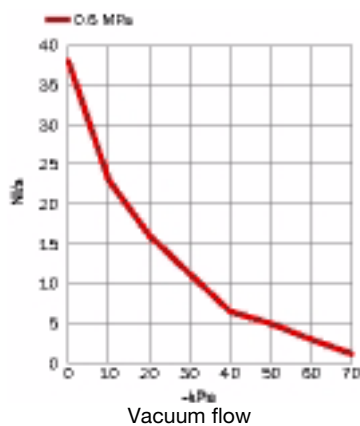

Ordering information

Description	Art. No.
Vacuum pump CLASSIC MP L200, conn. V, NBR sealings	0103624
Vacuum pump CLASSIC MP L200, conn. V, NBR sealings, complete with mounting brackets and silencer	0104140

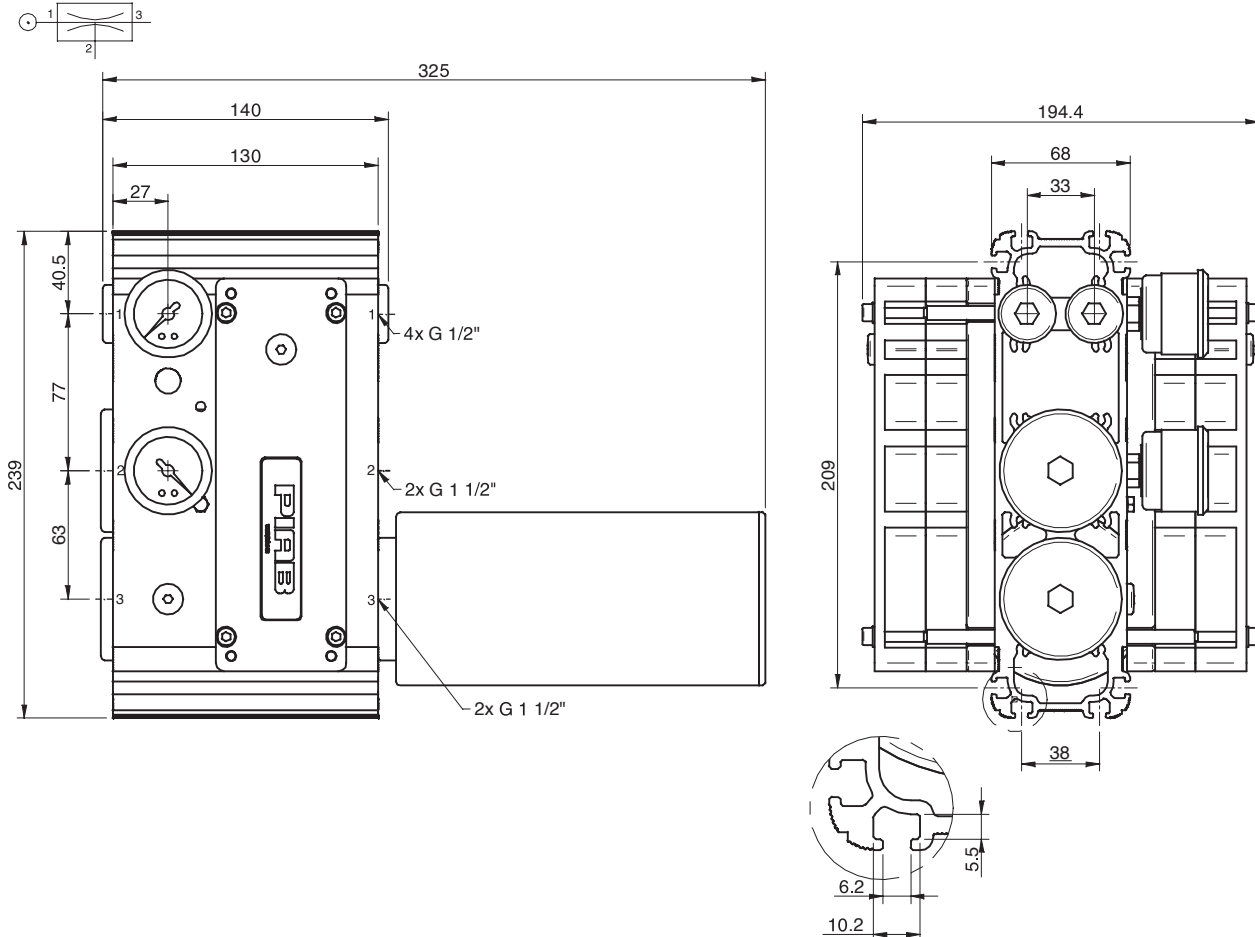

Classic MP

Ordering information, accessories

Description	Art. No.
Sealing kit CLASSIC MP, NBR	0104634

For CLASSIC MP 150–240 1x 0104634, for CLASSIC MP 300–480 2x 0104634. The sealing kit includes flap valves, gaskets, compressed-air filters and O-rings.