

P3010 Energy saving



- ▶ Patented multistage COAX® cartridge - MINI - with Pi, Si, Xi cartridge.
- ▶ Integrated air-saving function (ES Vacustat) that minimizes the air consumption by controlling the incoming air flow to the pump.
- ▶ Large hysteresis is recommended for sealed vacuum handling applications such as metal sheet, glass or plastic handling.
- ▶ Small hysteresis is recommended if a very accurate vacuum level has to be maintained in the process.
- ▶ Adjustable ES switch level.
- ▶ Pneumatic function.

Technical data

Description	Unit	Value
Feed pressure, max.	MPa	0.7
Noise level	dB(A)	66–68
Temperature range	°C	-10–50
Weight	g	197-349
Material		PP, PA, NBR, AI, SS
Signal range	-kPa	15-99
Function		2/2 NO
Flow at P1=6 bar and $\Delta p=0.5$ bar	NI/s	7.3
kv		10
Life span	cycles	>10,000,000

Performance tables

Depending upon choice of COAX® Cartridge, performance data of the P3010 can be found in the tables for vacuum flow, evacuation time and blow flow on the P3010 or COAX® Cartridge datasheets.

Ordering information

1. Select housing		P3010 Code
Housing, connection Ø=6 mm		00
2. COAX® cartridge modules		P3010 Code
COAX® cartridge module Pi12-3FSx1, non-return valve		AF
COAX® cartridge module Pi12-3FSx2, non-return valve		AH
COAX® cartridge module Si08-3FSx1, non-return valve		AB
COAX® cartridge module Si08-3FSx2, non-return valve		AD
COAX® cartridge module Xi10-3FSx1, non-return valve		AJ
COAX® cartridge module Xi10-3FSx2, non-return valve		AL
3. Select connection and function module		P3010 Code
B	Connection module high 6x1/8"	01
A	Connection module low 3x1/8"	02
4. Select ES		P3010 Code
ES Vacustat 2/2 NO, large hysteresis		AC
ES Vacustat 2/2 NO, small hysteresis		AD
5. Select vacuum sensing		P3010 Code
No vacuum sensing		00
Vacuum switch VS4016 G1/8" male, 30 -kPa		21
Vacuum switch VS4016 G1/8" male, 50 -kPa		22
Vacuum switch VS4016 G1/8" male, 70 -kPa		23
<i>For detailed information on VS4016, see separate datasheet.</i>		
Example		Ordering number
Housing, connection Ø 6 mm Pi12-3FSx1, non-return valve, Connection module high 6x1/8", ES Vacustat 2/2 NO, large hysteresis, no vacuum sensing		P3010.00.AF.01.AC.00

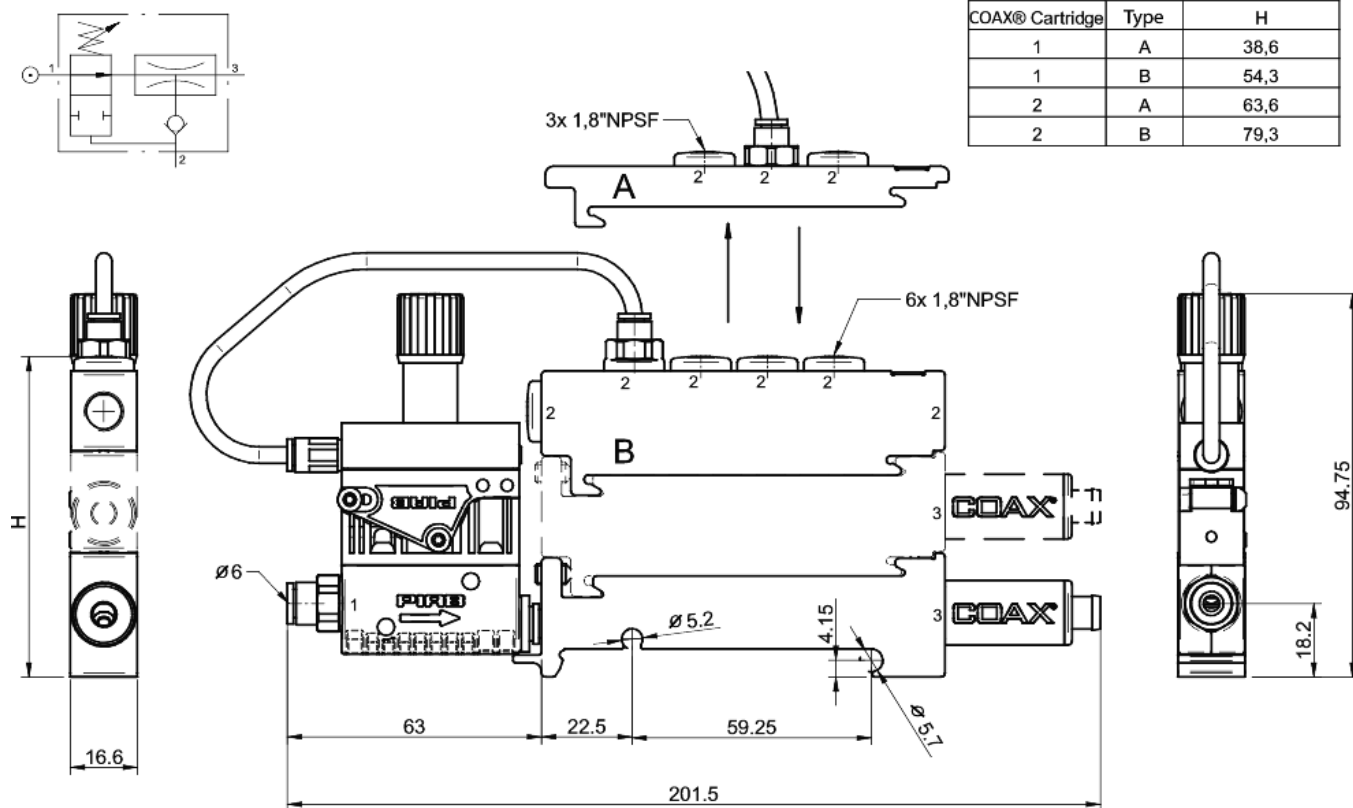

COAX® Cartridge	Type	H
1	A	38,6
1	B	54,3
2	A	63,6
2	B	79,3

Ordering information, accessories

Description	Art. No.
Sealing kit P3010, NBR	0104201

The sealing kit includes flap valves, compressed air filter and vacuum filter.