

## piFLOW<sup>®</sup>p



- ▶ Easy to maintain and clean
- ▶ Designed mainly for industries handling food, chemical and pharmaceutical products
- ▶ Solution that contributes to dust-free conveying
- ▶ Steel quality ASTM 316L
- ▶ COAX<sup>®</sup> patented technology
- ▶ Low sound level
- ▶ The filter bag has filtration 5 µm
- ▶ Automatic filter cleaning
- ▶ Rubber and plastic materials in conveyor are antistatic
- ▶ All materials in contact with the conveyed product fulfil the requirements of FDA, USDA and 3-A

### Technical data

Description	Unit	Value
Material		ASTM 316L, EPDM, NBR, ePTFE, PET, PE, PA, Al, SS, PP
Temperature range	°C	0-60
Weight	kg	40
Finish	Ra	0.6
Feed pressure, max.	MPa	0.7
Feed pressure range	MPa	0.4-0.6
Air consumption range	NI/s	20-28
Vacuum range	-kPa	60-75
Noise level range	dBA	69-77
Filter area	m <sup>2</sup>	0.42
Min particle size	µm	5.0
Material batch volume	l	14
Feed pressure, max. - actuator	MPa	0.4
Feed pressure, min. - fluidization	MPa	0.05
Feed pressure, max. - fluidization	MPa	0.15
Feed pressure range - control	MPa	0.4-0.6
Safety classification		IP54

### Vacuum flow

Feed pressure MPa	Air consumption NI/s	Vacuum flow (NI/s) at different vacuum levels (-kPa)								Max vacuum -kPa
		0	10	20	30	40	50	60	70	
0.40	20	64	42	30	19.2	12.8	6.4	1.6	-	60
0.50	24	73	46	35	22.4	13.6	9.9	5.6	2.9	70
0.60	28	77	48	42	27	14.4	9.6	8.0	5.6	75

### Ordering information

Description	Product code
piFLOW®p, piPREMIUM400, Textile filter 04, Hose Inlet Ø 51 (2"), Volume 14L, Cone opening, bridging, Control CU-2B, Antistatic & AL, No special documentation, Manual GB	P.P400.TX4.51.14.CB.2B.AAL.0.GB

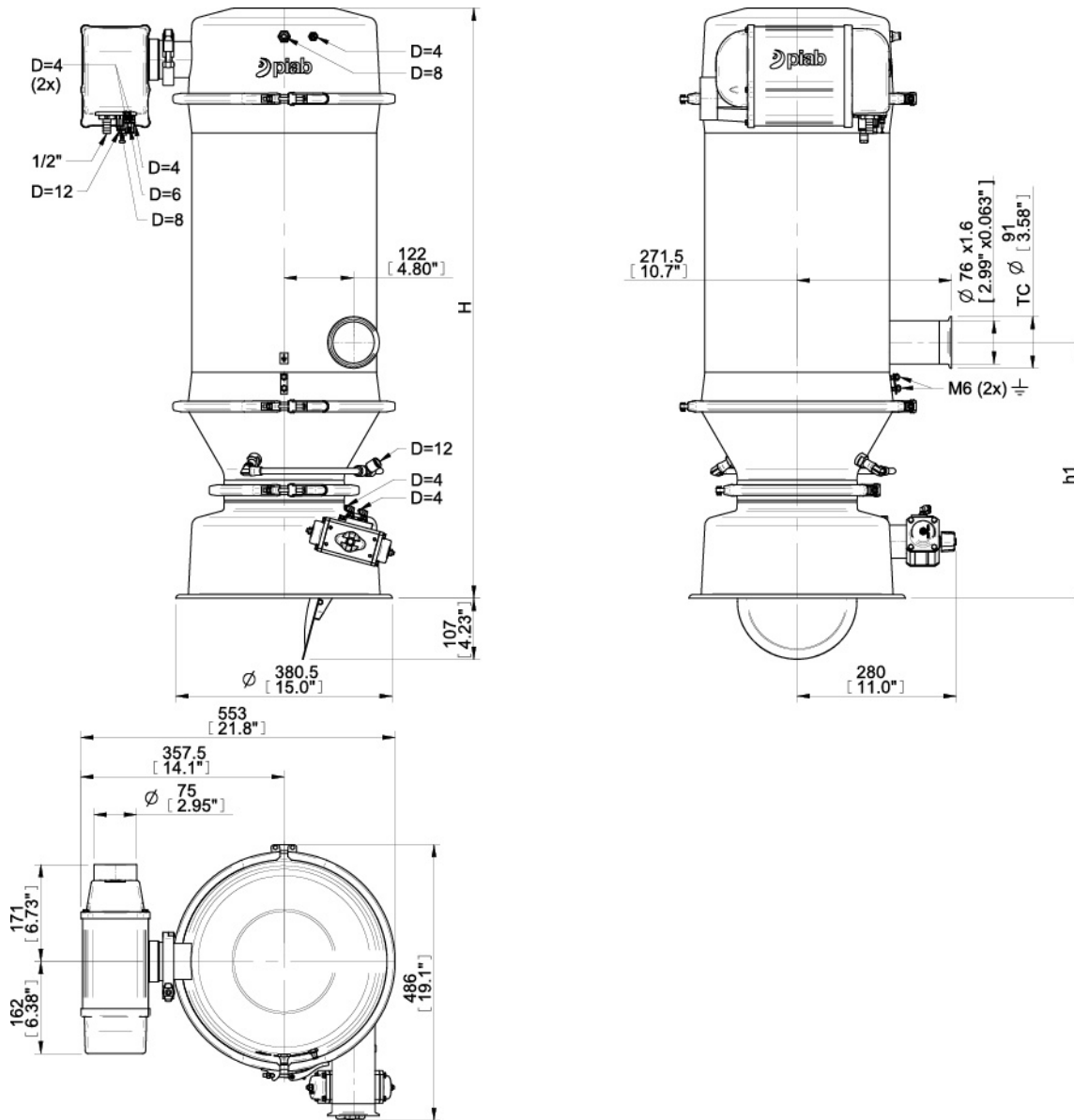

H	1038 [40.9"]
h1	450 [17.7"]

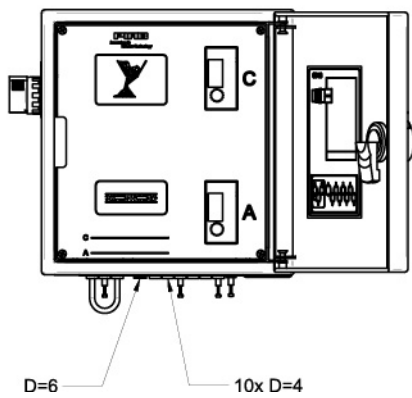
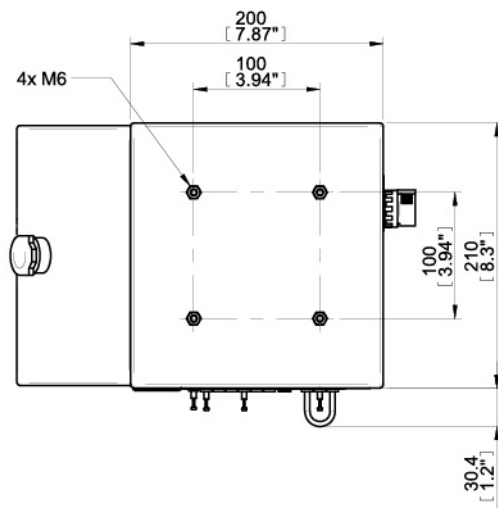
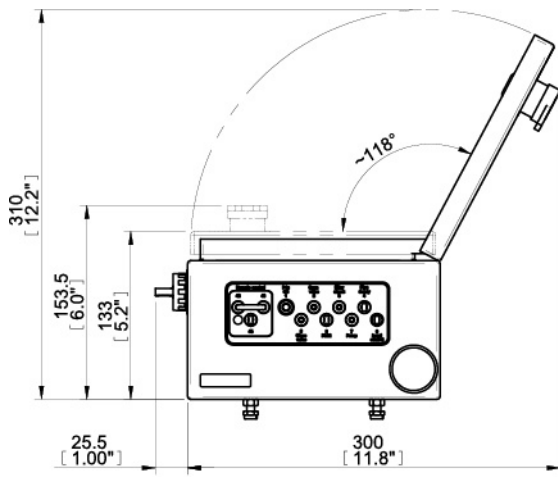
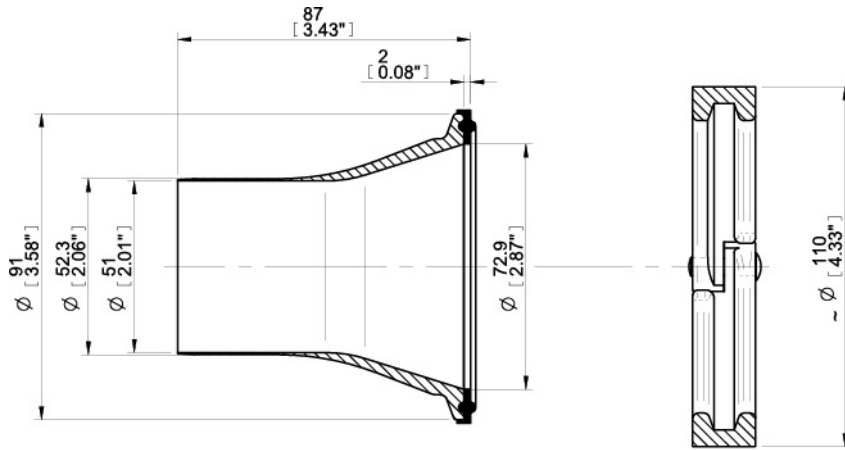

### Ordering information, recommended spare parts

Description	Art. No.
Textile filter D=125 L=360	0115356
Filter seal 125 NBR	0103953/1
Module Filter plate seal 33 NBR	0103949/1
Module Filter plate seal 21 NBR	0103947/1
Module fluid seal 33 NBR	0103950/1
Fluid seal 33 NBR	0103951/1
Fluidising cone Black 33	0103978/1

### Ordering information, recommended accessories

Description	Art. No.
Pinch valve DN50 (4bar) hose connection	3404630
Pinch valve DN50(8bar) female thread	3404626
Pipe bend D=50 R=500 90° SS	3404660
Pipe fitting 75 x 50	3404120
Pipe fitting 50 x 50	3404121
Pipe fitting Y 3x50	3404144
Pipe line emptying unit 50	0121294
Feed adapter cpl	0117681
Feed adapter cpl NBR	0117667
Feed Nozzle Ø50	3104054
Feed station C Fluid 40 L NBR	0117678
Capacitive Sensor M32 4-wire DC PNP	0124098
Capacitive Sensor M32 5-wire DC PNP ATEX	0124099
Valve unit for level detector CU-1/2	0124051
Filter regulator to pump 1/2"	0104490
Container module 33/26	0103857
Container module 33/12	0103860
Cone module 33/15	0103858
Container 33/16	0103856
Mounting girdle cpl. 33	0128727
Flange for welding 33/2	0107880