

piFLOW[®]p



- ▶ Easy to maintain and clean
- ▶ Designed mainly for industries handling food, chemical and pharmaceutical products
- ▶ Solution that contributes to dust-free conveying
- ▶ Steel quality ASTM 316L
- ▶ COAX[®] patented technology
- ▶ Low sound level
- ▶ The filter bag has filtration 5 µm
- ▶ Automatic filter cleaning
- ▶ Rubber and plastic materials in conveyor are antistatic
- ▶ All materials in contact with the conveyed product fulfil the requirements of FDA, USDA and 3-A

Technical data

Description	Unit	Value
Material		ASTM 316L, EPDM, NBR, ePTFE, PET, PA, Al, SS, PP
Temperature range	°C	0-60
Weight	kg	85
Finish	Ra	0.6
Feed pressure, max.	MPa	0.7
Feed pressure range	MPa	0.4-0.6
Air consumption range	NI/s	60-84
Vacuum range	-kPa	60-75
Noise level range	dBA	69-77
Filter area	m ²	1.61
Min particle size	µm	5.0
Material batch volume	l	56
Feed pressure, max. - actuator	MPa	0.4
Feed pressure range - control	MPa	0.4-0.6

Vacuum flow

Feed pressure MPa	Air consumption NI/s	Vacuum flow (NI/s) at different vacuum levels (-kPa)								Max vacuum -kPa
		0	10	20	30	40	50	60	70	
0.40	60	240	139	91	58	38	19.2	4.8	-	60
0.50	72	274	158	106	67	41	30	16.8	8.6	70
0.60	84	288	168	125	82	43	29	24.0	16.8	75

Ordering information

Description	Product code
piFLOW®p, piPREMIUM1200, Textile filter 06, Hose Inlet Ø 76 (3"), Volume 56L, Cone opening, Control PPT/RS, Antistatic & AL, No special documentation, Manual RU	P.P120L.TX6.76.56.C.RS.AAL.0.RU

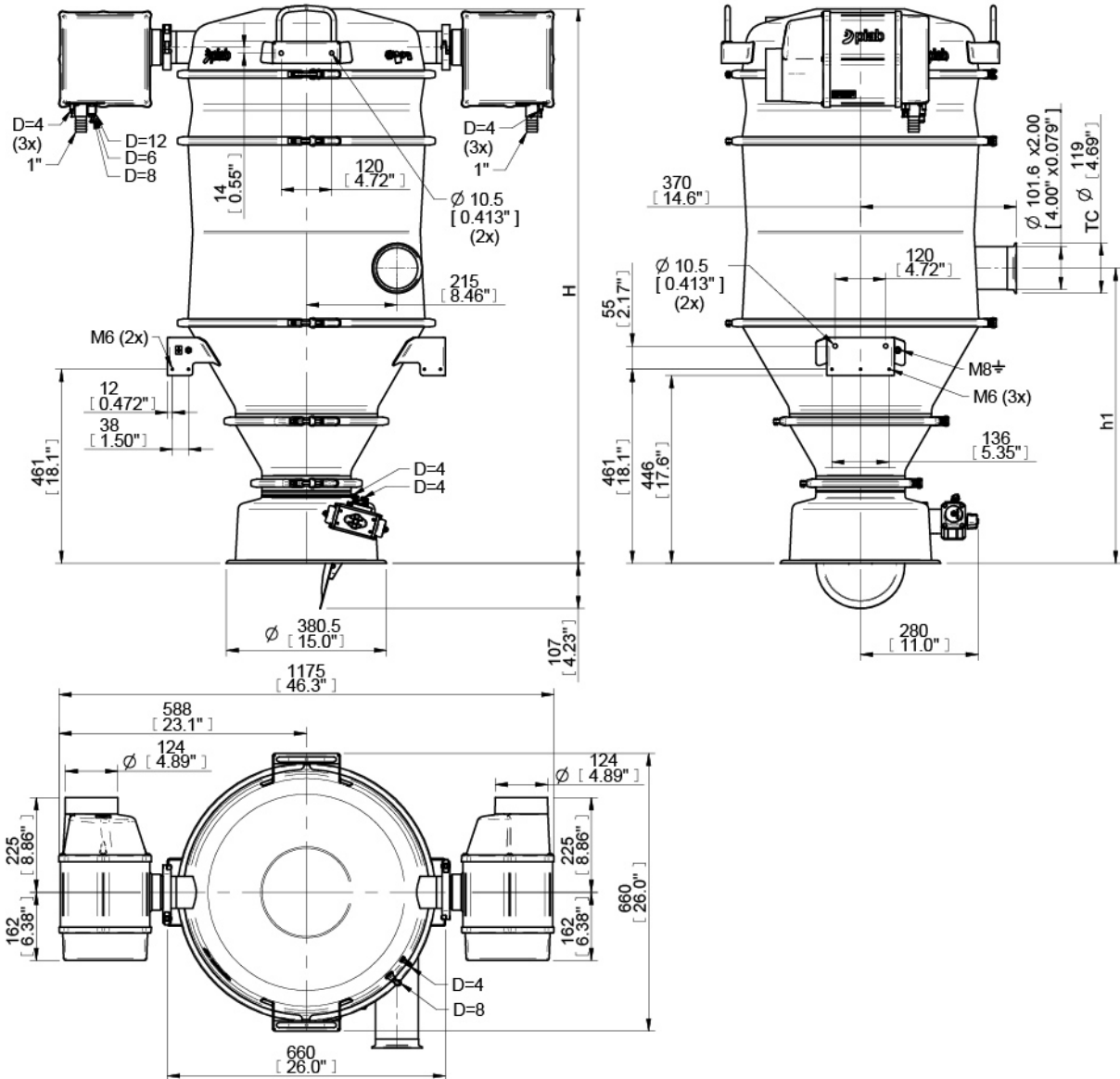

H	1598 [62.9"]
h1	701 [27.6"]

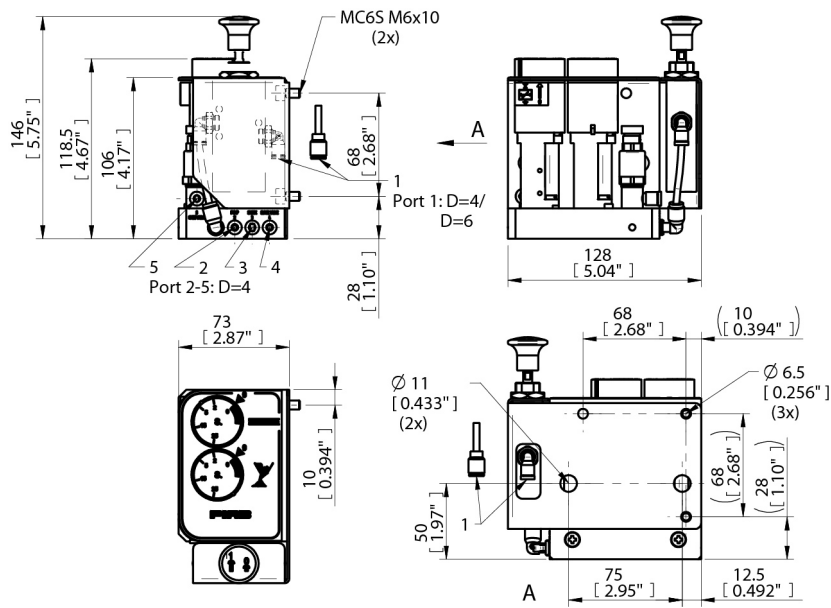
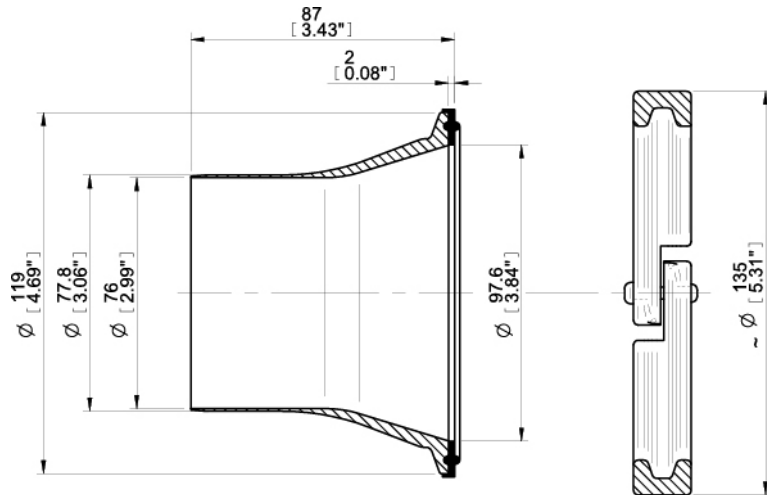

Ordering information, recommended spare parts

Description	Art. No.
Textile filter D=125 L=610	0115357
Filter seal 125 NBR	0103953/1
Module Filter plate seal 56 NBR	0106143/1
Module Filter plate seal 21 NBR	0103947/1
Module seal 33 NBR	0103948/1
Module seal 56 NBR	0106142/1
Bottom valve seal 180 NBR	0103952/1

Ordering information, accessories

Description	Art. No.
Pinch valve DN80 (8 bar) internal thread	3404628
Pipe bend Ø75 - 90°	3404668
Pipe fitting straight 75x75	3404119
Pipe fitting straight reducer 75x50	3404120
Pipe fitting straight reducer 100x75	3404138
Pipe fitting Y 3x75	3404143
Pipe line emptying unit 75	0121312
Hose connector TC3"OD - Ø76 cpl	0201795
Hose connector TC4"OD - Ø76 cpl	0201798
Feed adapter 75U flange	0117682
Feed adapter D=75, NBR clamp ring	0117669
Feed station 40 litres, NBR	0117673
Filter regulator kit 1" 1200-1600	0201782
Wall mounting kit pump piPREMIUM1200-1600	0201786
Maintenance kit cpl/Pumps	0201649
Container module 33/26	0103857
Container module 33/12	0103860
Container module 56/16	0106179
Container module 56/43	0106178
Cone module 33/15	0103858
Cone module 56/23	0106182
Cone module with mounting brackets 56/23	0106680
Container 33/16	0103856
Container 56/26	0106189
Flange for welding 56/2	0108523
Container module half 56/8	0108526
Flange for welding 33/2	0107880
Container module half 33/13	0107510
Container module half 33/6	0107509