

Suction cup F30-2 Silicone, G1/8" male/M5 female PA, F30-2.20.02CD



- Suitable for flat objects.
- Good stability and little inherent movement.
- Recommended when the lifting force is parallel to the surface of the object.
- Cleats prevent thin, sensitive objects from being deformed and gives extra friction when the lifting force is parallel.

General

Curve radius	0.98 in
Movement, vertical max.	0.06 in
Application	Dry sheet metal
Material	Silicone (SIL)
Suction cup model	F
Suction cup shape	Flat
Volume	0.12 in ³
Weight	0.08 oz

Fitting

Fitting size	1/8", M5
Fitting style	Female/Male
Fitting type	G-thread, M-thread
Fitting option	None

Dimension

Height	0.78 in
Outer diameter	1.26 in
Outer diameter, actuated	1.28 in

Performance — lifting forces

		
6 -inHg	2.7 lbf	2.47 lbf
18 -inHg	5.62 lbf	3.6 lbf
27 -inHg	6.97 lbf	4.5 lbf

Material

	Silicone (SIL)
Color	Red
Hardness	50 Shore A
Temperature	-40 – 392 °F

Material resistance

	Silicone (SIL)
Alcohol	++
Concentrated acids	-
Ethanol	N/A
Hydrolysis	+
Methanol	N/A
Oil	-
Oxidation	+++
Gasoline	-
Wear resistance	++
Weather and ozone	+++

Dimensional drawings

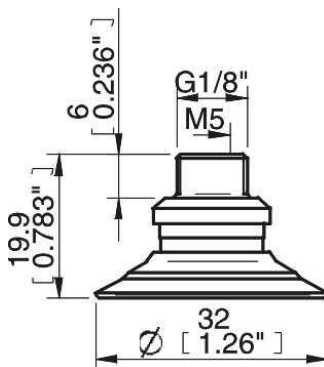

Spare parts

	Part no.
Suction cup F30-2 Silicone	F30-2.20
Fitting G1/8" male/M5 female, PA	02CD

Accessories

	Part no.
Suction cup F30-2 Chloroprene	F30-2.10
Suction cup F30-2 Chloroprene, for fitting with cone valve	31.50.239
Fitting M5 female	02AA
Fitting M5 female, with dual flow control valve	02DA
Fitting G1/8" male, with mesh filter	02AB
Fitting G1/8" male/M5 female, with mesh filter	02AF
Fitting G1/8" male/M5 female, with dual flow control valve	02DD
Fitting G1/8" male/M5 female, with cone valve	02UV
Fitting 5xM5 female	02AE
Fitting 5xM5 female, with dual flow control valve	02DE
Fitting 1/8" NPT male, with dual flow control valve	02DC
Fitting 1/8" NPT male, with mesh filter	02AC
Fitting G1/8" male/M5 female	02AD
Suction cup F30-2 Silicone, for fitting with cone valve	