

# Suction cup F30-2 Silicone, G1/8" male/M5 female, with mesh filter, F30-2.20.02AF



- Suitable for flat objects.
- Good stability and little inherent movement.
- Recommended when the lifting force is parallel to the surface of the object.
- Cleats prevent thin, sensitive objects from being deformed and gives extra friction when the lifting force is parallel.



## General

Curve radius	0.98 in
Movement, vertical max.	0.06 in
Application	Dry sheet metal
Material	Silicone (SIL)
Suction cup model	F
Suction cup shape	Flat
Volume	0.12 in <sup>3</sup>
Weight	0.08 oz

## Fitting

Fitting size	1/8", M5
Fitting style	Female/Male
Fitting type	G-thread, M-thread
Fitting option	Filter mesh

## Dimension

Height	0.70 in
Outer diameter	1.26 in
Outer diameter, actuated	1.28 in

## Performance — lifting forces

		
6 -inHg	2.7 lbf	2.47 lbf
18 -inHg	5.62 lbf	3.6 lbf
27 -inHg	6.97 lbf	4.5 lbf

## Material

	Silicone (SIL)
Color	Red
Hardness	50 Shore A
Temperature	-40 – 392 °F

## Material resistance

	Silicone (SIL)
Alcohol	++
Concentrated acids	-
Ethanol	N/A
Hydrolysis	+
Methanol	N/A
Oil	-
Oxidation	+++
Gasoline	-
Wear resistance	++
Weather and ozone	+++

## Dimensional drawings

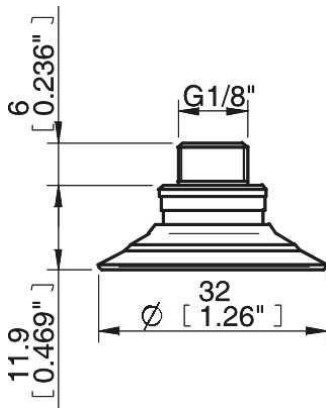

## Spare parts

	Part no.
Suction cup F30-2 Silicone	F30-2.20
Fitting G1/8" male/M5 female, with mesh filter	02AF

## Accessories

	Part no.
Suction cup F30-2 Chloroprene	F30-2.10
Suction cup F30-2 Chloroprene, for fitting with cone valve	31.50.239
Fitting M5 female	02AA
Fitting M5 female, with dual flow control valve	02DA
Fitting G1/8" male, with mesh filter	02AB
Fitting G1/8" male/M5 female, with dual flow control valve	02DD
Fitting G1/8" male/M5 female, with cone valve	02UV
Fitting 5xM5 female	02AE
Fitting 5xM5 female, with dual flow control valve	02DE
Fitting G1/8" male/M5 female, PA	02CD
Fitting 1/8" NPT male, with dual flow control valve	02DC
Fitting 1/8" NPT male, with mesh filter	02AC
Fitting G1/8" male/M5 female	02AD
Suction cup F30-2 Silicone, for fitting with cone valve	