

COAX® in piGRIP® Si, 0200345



- Fully decentralized vacuum unit based on patented COAX® technology.
- Quickest response time and very high energy efficiency.
- Easy system dimensioning – small risk for mistakes.
- Available with a variation of two-stage COAX® MICRO cartridges.
- Suitable for high vacuum flow.
- Suitable for extra capacity/dirt tolerance.

General

Material	CuZn, PA, Al, Nitrile (NBR)
Noise level	55 – 61 dBA
Temperature	-10 – 80 °C
Weight	45 g

Performance

Feed pressure, max.	0.7 MPa
---------------------	---------

Vacuum flow

Feed pressure MPa	Air consumption NI/s	Vacuum flow (NI/s) at different vacuum levels (-kPa)									Max vacuum -kPa
		0	10	20	30	40	50	60	70	75	
0.6	0.12	0.28	0.21	0.12	0.08	0.07	0.06	0.04	0.02	75	

Evacuation time

Feed pressure MPa	Air consumption NI/s	Evacuation time (s/l) to reach different vacuum levels (-kPa)								Max vacuum -kPa
		10	20	30	40	50	60	70	75	
0.6	0.12	0.41	1.01	2.01	3.3	4.9	6.9	10.2	75	

Blow flow

Feed pressure MPa	Air consumption NI/s	Blow flow (NI/s) at different pressure levels (kPa)									Max pressure kPa
		0	10	20	30	40	50	60	70	70	
0.6	0.12	0.4	0.34	0.22	0.21	0.2	0.18	0.17	0.15	70	

Dimensional drawings

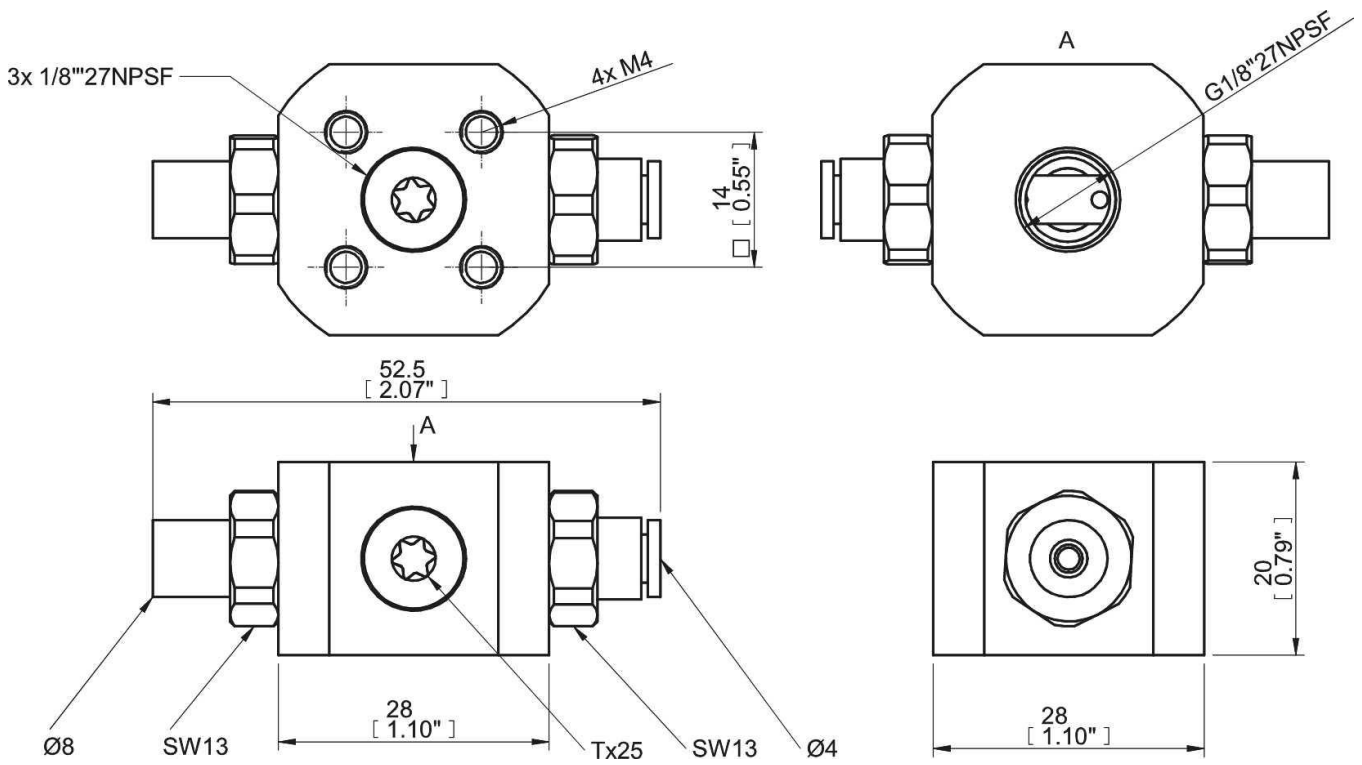

Accessories

	Item no.
Mounting kit M6/22 07 top VGS3010	0108488
Mounting kit 4xM4 VGS3010	0106915
Mounting kit M8/16 VGS3010	0106927
Mounting kit M8/27 04 VGS3010	0106949