

Bellows suction cup

S.B110-2S50.G38F.50



- ▶ The lifting movement can be used to separate small and thin objects.
- ▶ Only lightweight objects should be handled when the lifting force is parallel to the surface of the object, in order to achieve good precision and safe lifting movement.
- ▶ Suitable for level adjustment. Several short bellows in one lifting device can handle objects with height differences and varying shapes, for example embossed or corrugated plates.
- ▶ With mesh filter.

Lifting force

Description	Vertical		
	20 -kPa	60 -kPa	90 -kPa
Lifting forces	137.0 N	343.0 N	461.0 N

Technical data

Description	Unit	Value
Internal volume	cm ³	310.0
Weight	g	244
Min. curve radius -60 kPa	mm	60.0
Max. vertical movement	mm	34.6
Application	-	Dry sheet metal, Corrugated / cardboard,
Material	-	Silicone (SIL)
Colour	-	Red
Suction cup model	-	B
Suction cup shape	-	Bellows
Hardness °Shore A	-	50 °Shore A
Temperature range (°C)	°C	-40 – 200
Actuated outer diameter, max	mm	130

Fitting

Description	Value
Fitting size	3/8"
Fitting style	Female
Fitting type	G-Thread
Fitting material	CuZn, SS, Al, NBR
Fitting option	Filter mesh and filter disc

Material resistance , Silicone, SIL

Description	Value
Alcohol	Good
Concentrated Acids	Poor
Ethanol	N/A
Hydrolysis	Fair
Methanol	N/A
Oil	Poor
Oxidation	Excellent
Petrol	Poor
Wear Resistance	Good
Weather & Ozone	Excellent

Values specified in data sheet are tested at:

- Room temperature (20°C [68°F] ± 3°C [5.5°F]).
- Standard atmosphere (101.3 [29.9 inHg] ± 1.0 kPa [0.3 inHg]).
- Relative humidity 20-70%.
- Compressed air quality, DIN ISO 8573-1 class 4.

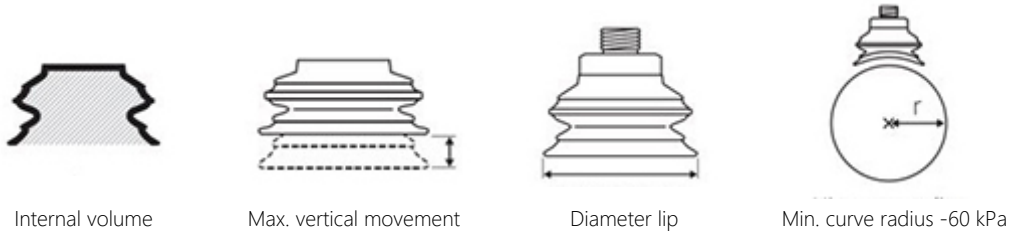

Dimensional drawing

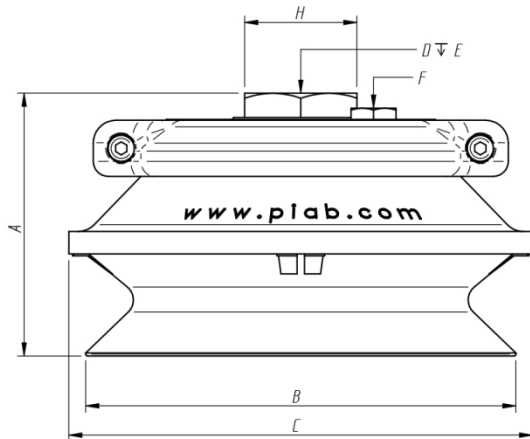

Product code	Description	Unit	Value
A	Building height	mm [inch]	70.6 [2.78"]
B	Diameter lip	mm [inch]	115.0 [4.53"]
C	Diameter (bellow)	mm [inch]	126.0 [4.96"]
D	Thread	-	G3/8"
E	Thread height	mm [inch]	22.0 [0.87"]
H	Keygrip	mm	SW 30

Ordering information

Description	Product code
Bellows suction cup , Ø 110mm model 2, Silicone, SIL, 50 °Shore A, G-Thread, 3/8", Female, Filter mesh and filter disc	S.B110-2S50.G38F.50

Ordering information, spare parts

Description	Art. No.
Fitting 110 G3/8" female, with mesh filter	0100557
Suction cup B110-2 Silicone with filter	0101945
Filter D=118, 10 pcs, for B110-2	0201150

Ordering information, accessories

Description	Art. No.
Fitting 110, G1/2" female, with mesh filter	0100561
Fitting 110, 3/8" NPSF female, with mesh filter	0100559
Suction cup B110-2 Nitrile-PVC with filter	0101944
Suction cup B110-2 Silicone FCM with filter	0200486

Storage guidelines (scan QR code)

