

Bellows suction cup

S.B110HN75.G38F.01



- ▶ The lifting movement can be used to separate small and thin objects.
- ▶ Only lightweight objects should be handled when the lifting force is parallel to the surface of the object, in order to achieve good precision and safe lifting movement.
- ▶ Suitable for level adjustment. Several short bellows in one lifting device can handle objects with height differences and varying shapes, for example embossed or corrugated plates.
- ▶ With mesh filter.

Lifting force

Description	Vertical		
	20 -kPa	60 -kPa	90 -kPa
Lifting forces	137.0 N	343.0 N	461.0 N

Technical data

Description	Unit	Value
Internal volume	cm ³	310.0
Weight	g	241
Min. curve radius -60 kPa	mm	60.0
Max. vertical movement	mm	34.6
Application	-	Dry sheet metal, Glass handling, High/low temp cup (plastic), Plastic injection molded parts,
Material	-	Hydrogenated Nitrile (HNBR)
Colour	-	Blue
Suction cup model	-	B
Suction cup shape	-	Bellows
Hardness °Shore A	-	75 °Shore A
Temperature range (°C)	°C	-30 – 140
Actuated outer diameter, max	mm	129

Fitting

Description	Value
Fitting size	3/8"
Fitting style	Female
Fitting type	G-Thread
Fitting material	CuZn, SS, Al, NBR
Fitting option	Filter mesh

Material resistance , Hydrogenated Nitrile, HNBR

Description	Value
Alcohol	Good
Concentrated Acids	Fair
Ethanol	N/A
Hydrolysis	Good
Methanol	N/A
Oil	Excellent
Oxidation	Excellent
Petrol	Excellent
Wear Resistance	Excellent
Weather & Ozone	Excellent

Values specified in data sheet are tested at:

- Room temperature (20°C [68°F] ± 3°C [5.5°F]).
- Standard atmosphere (101.3 [29.9 inHg] ± 1.0 kPa [0.3 inHg]).
- Relative humidity 20-70%.
- Compressed air quality, DIN ISO 8573-1 class 4.

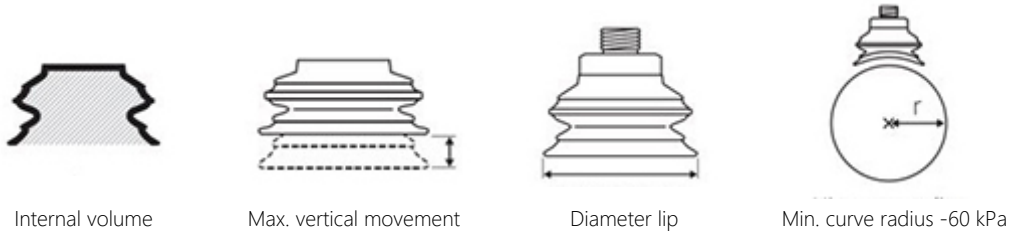

Dimensional drawing

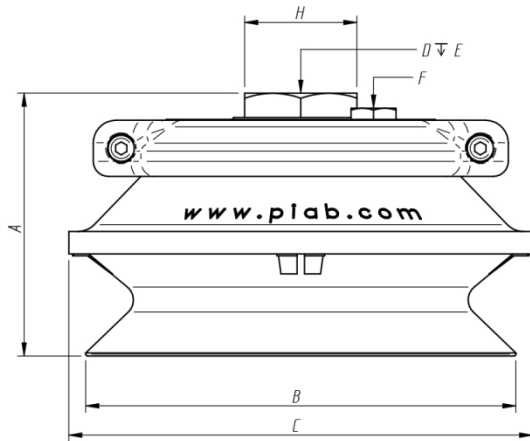

Product code	Description	Unit	Value
A	Building height	mm [inch]	70.6 [2.78"]
B	Diameter lip	mm [inch]	115.0 [4.53"]
C	Diameter (bellow)	mm [inch]	124.0 [4.88"]
D	Thread	-	G3/8"
E	Thread height	mm [inch]	22.0 [0.87"]
H	Keygrip	mm	SW 30

Ordering information

Description	Product code
Bellows suction cup , Ø 110mm, Hydrogenated Nitrile, HNBR, 75 °Shore A, G-Thread, 3/8", Female, Filter mesh	S.B110HN75.G38F.01

Ordering information, spare parts

Description	Art. No.
Fitting 110 G3/8" female, with mesh filter	0100557
Suction cup B110 HNBR	3150108T

Ordering information, accessories

Description	Art. No.
Fitting 110, G1/2" female, with mesh filter	0100561
Fitting 110, 3/8" NPSF female, with mesh filter	0100559
Suction cup B110 Nitrile-PVC	3150108P
Suction cup B110 Silicone	3150108S
Suction cup B110 Silicone FCM	0200246

Storage guidelines (scan QR code)

