



Item no: 9909666

## Suction cup F20 Silicone FCM, 1/8" NPT male, with mesh filter

The material used is food grade silicone material. It is free from colour pigments, approved by FDA (FDA 21 CFR 177.2600. ) and meets EU's regulation EU 1935/2004.(FDA approved). The cup is soft and pliable and can operate at a wide temperature range.

- The silicone material complies with FDA 21 CFR 177.2600 & EU 1935/2004.
- Suitable for flat objects.
- Good stability and little inherent movement.
- Recommended when the lifting force is parallel to the surface of the object.
- Cleats prevent thin, sensitive objects from being deformed and gives extra friction when the lifting force is parallel.

### General

Application	Food contact materials (FDA & EU), non-detectable
Suction cup shape	Flat
Material	Silicone (SIL FDA)
Suction cup model	F
Weight	1.2 g
Volume	1 cm <sup>3</sup>
Suction cup model	F20
Movement, vertical max.	1.2 mm
Curve radius, min.	18 mm



### Fitting

Fitting option	Filter mesh
Fitting size	1/8"
Fitting style	Male
Fitting type	NPT-thread

Dimension

Height	20 mm
Outer diameter	22 mm

Performance - lifting forces

	F20		
20 -kPa		6 N	5 N
60 -kPa		14.5 N	8 N
90 -kPa		19 N	8.5 N

Material

Name	SILFDA
Colour	Transparent
Temperature	-40 - 200 °C
Hardness	50 °Shore A

	SILFDA
Alcohol	++
Concentrated acids	-
Ethanol	n/a
Hydrolysis	+
Methanol	n/a
Oil	-
Oxidation	+++
Petrol	-
Wear resistance	++
Weather and ozone	+++

Dimensional drawings 

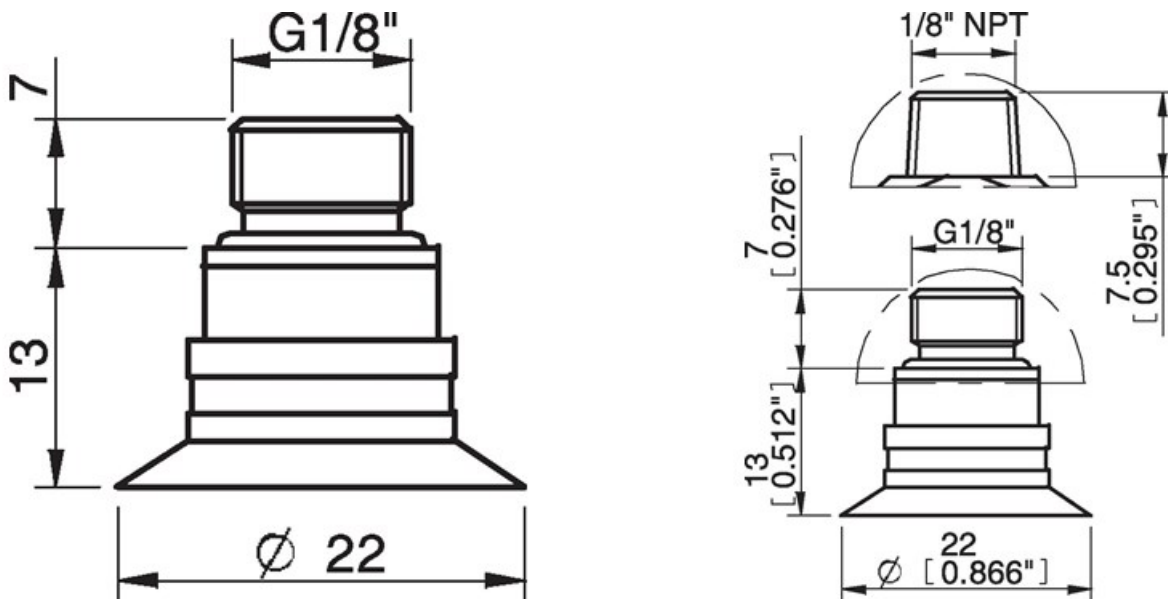

Values specified in the data sheet are tested at:

- Room temperature: (20° C [68° F] ± 3° C [5.5° F])
  - Standard atmosphere: (101.3 [29.9 inHg] ± 1.0 kPa [0.3 inHg])
  - Relative humidity: 0-100%
  - Compressed air quality: DIN ISO 8573-1 class 4
- 

#### Accessories

3250085 | Fitting G1/8" male, with mesh filter

0101152 | Fitting G1/8" male/M5 female, with mesh filter

#### Spare parts

0200417 | Suction cup F20 Silicone FCM

3250088 | Fitting 1/8" NPT male, with mesh filter